

**FONESTAR**

**SAL-622N**  
PAIR OF ADJUSTABLE WALL  
MOUNTS FOR LOUDSPEAKERS

EN Instruction manual

CE



## DESCRIPTION

- Pair of adjustable wall mounts for loudspeakers.
- Horizontally adjustable 120°.
- Vertical tilt  $\pm 20^\circ$ .
- Maximum borne weight: 10 kg.
- Colour: black.
- Dimensions:
  - Total: 65 x 151 x 115 mm depth.
  - Wall plate: 48 x 115 mm.
  - Loudspeaker mount: 65 x 145 mm with 5.25 mm holes with separation between screws of approximately 50 mm .

## ASSEMBLY INSTRUCTIONS

**CAUTION:** make sure that the surface where you are to install the mount is resistant enough and completely flat.

### ACCESSORIES INCLUDED

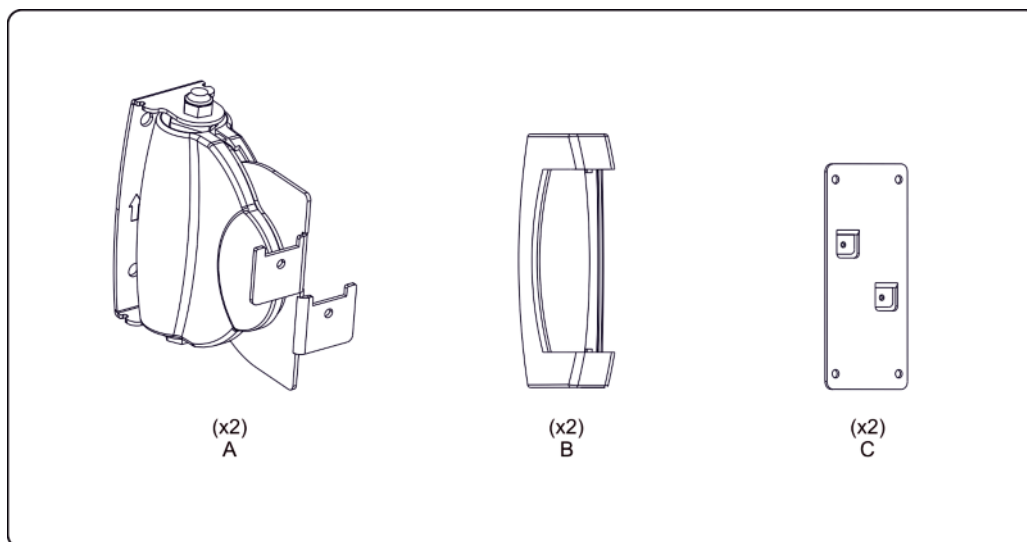

#### M accessories

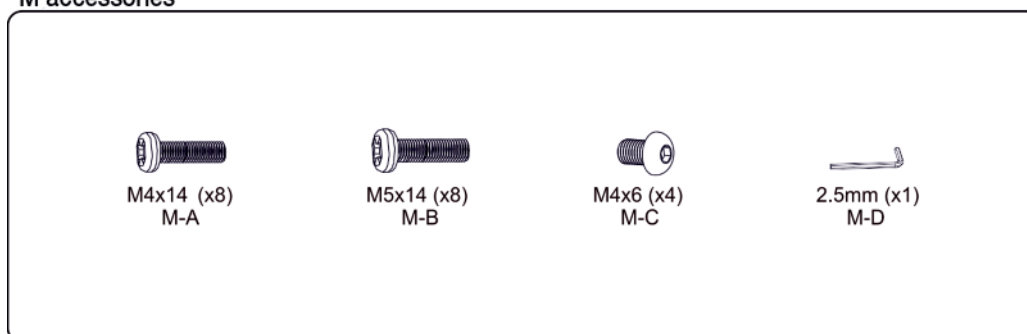

#### W accessories



1.-

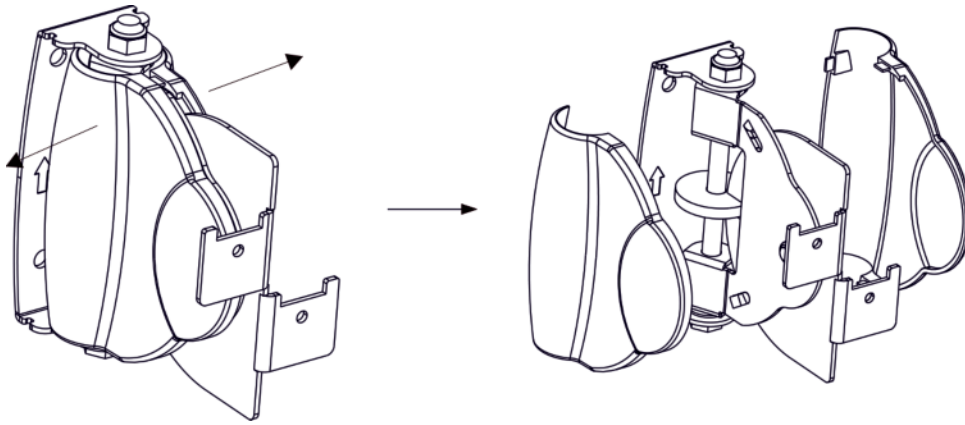

## 2.- FIXING THE MOUNTS TO THE WALL

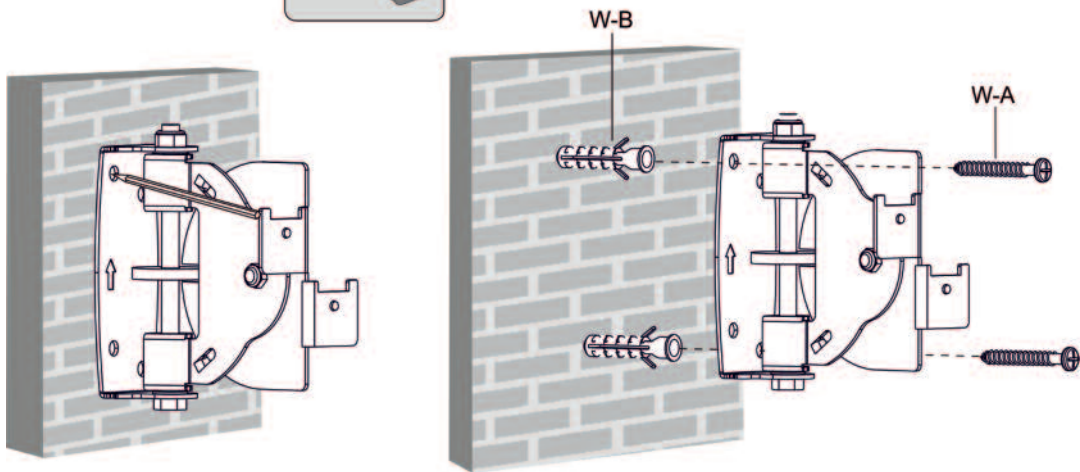

## 3.- ADJUSTING THE VERTICAL TILT OF THE MOUNT

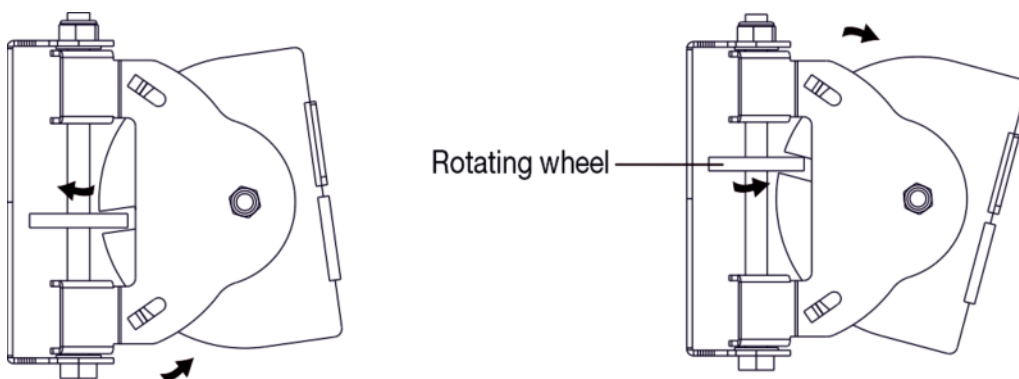

4.-

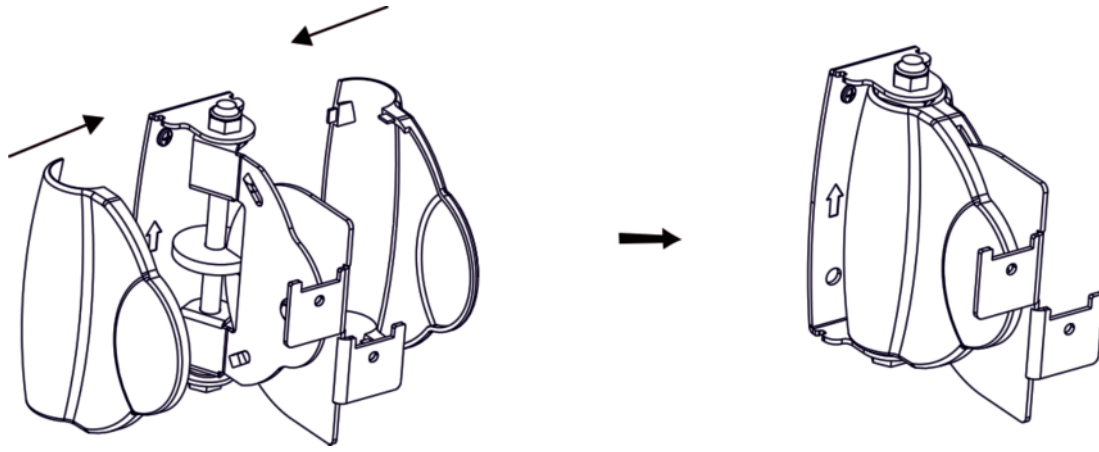

5.-

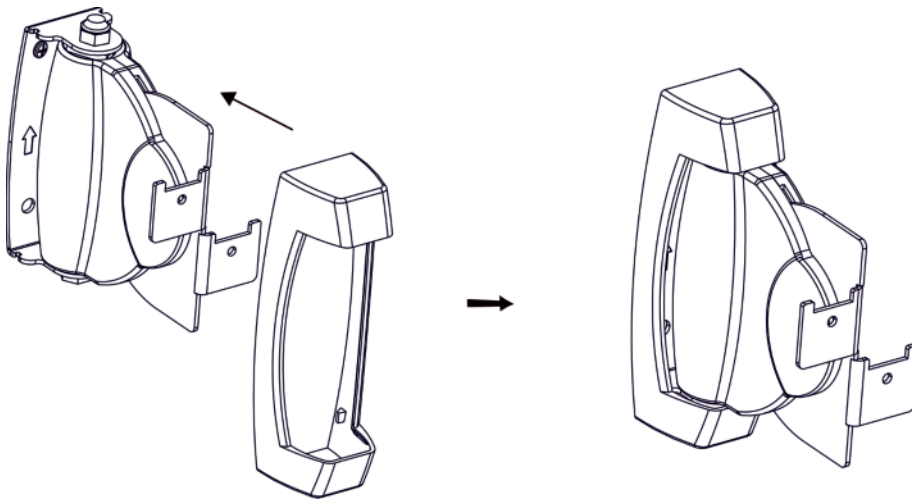

**6.- ASSEMBLING THE LOUDSPEAKER MOUNT**

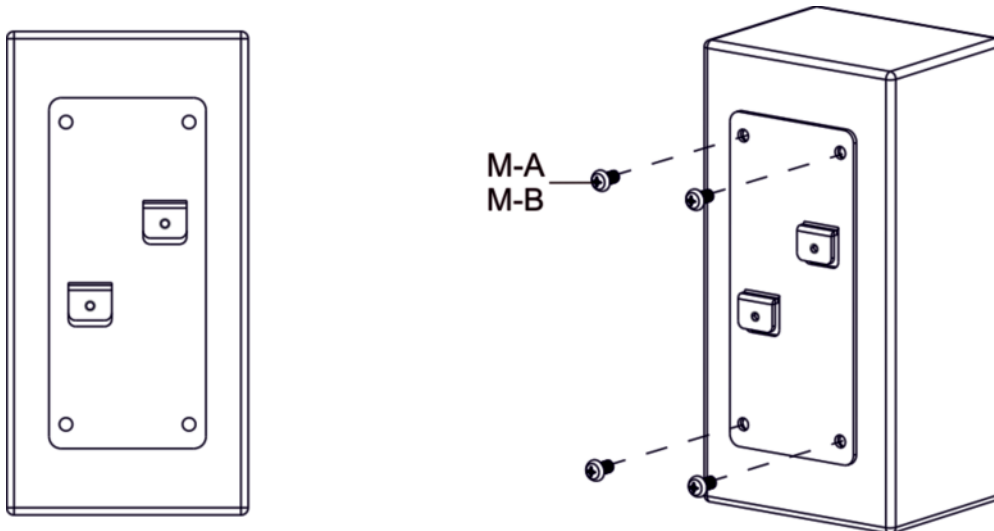

## 7.- ATTACHING THE LOUDSPEAKERS TO THE MOUNTS

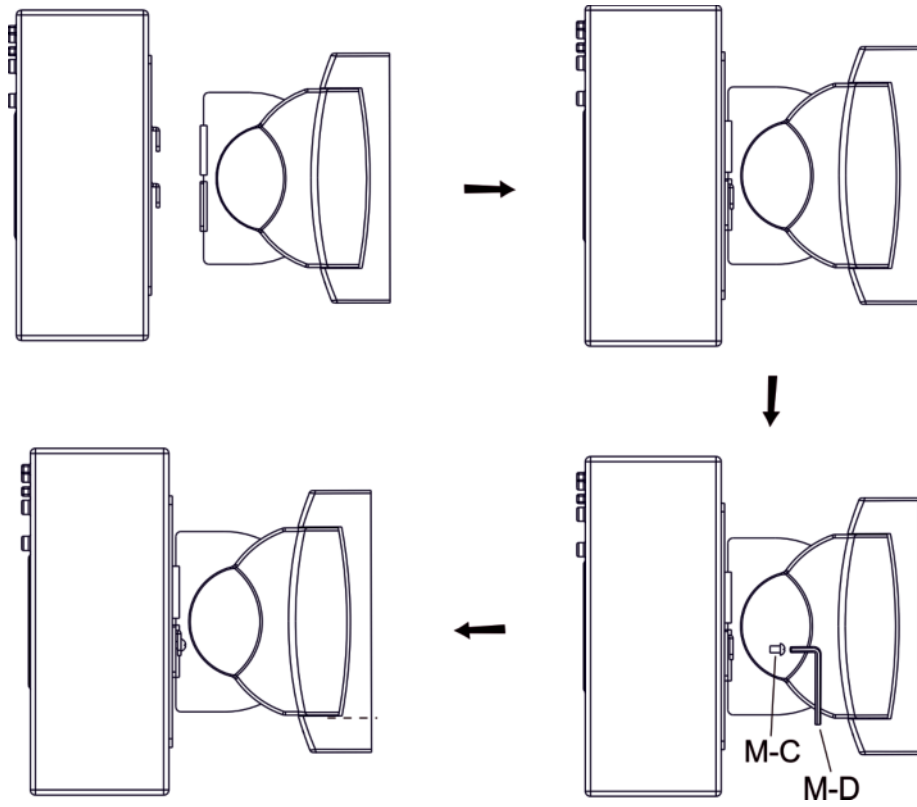

## IMPORTANT

- 1.- The installation surface must be completely flat. Make sure the holes in the wall coincide with the holes on the plate. Bolt the mount to the wall, in vertical position only.
- 2.- The mount must be properly and firmly attached to the wall or installation surface to make sure that the support holds the maximum weight. **FONESTAR** does not hold itself responsible for damage or breakages due to the mount falling away from the wall because it was incorrectly attached, the wall was in bad conditions or it was handled incorrectly.

### WARRANTY

This product has been tested and has passed the corresponding quality control prior to being put on the market.

**FONESTAR** guarantees the suitability of the product for its specified use during a period of 2 years from the delivery date and commits itself to repair or substitute the goods as expressed in the Spanish law 'La Ley General para la Defensa de los Consumidores y Usuarios, Real Decreto Legislativo 1/2007 16 Noviembre.

The lack of conformity in the first six months after purchase, due to a manufacturing defect, will be rectified with no more than showing the proof of purchase. After six months **FONESTAR** reserves the right to demand proof of the product being sold with that problem.

This warranty does not include damage produced by: inappropriate use or negligence, accidents, worn out parts due to use, breakages, burns, spilt liquids or other substances, excessive humidity, battery deterioration and internal manipulation of the device, the software or its components by unauthorized persons, and in general any use that is unrelated to the nature and purpose of the product.

If any service is needed during the warranty period because of lack of conformity, please contact the business or distributor where the product was purchased in no more than 2 months after being conscious of the problem. It is only necessary to contact **FONESTAR** if it is impossible or imposes an undue burden for them to solve it.

To benefit from this warranty it is necessary to show the proof of purchase with the date clearly visible, with no corrections or crossing out.

This document adds information, and never decreases the consumers' rights, which in all cases are protected by the Spanish law 'La Ley General para la Defensa de los Consumidores y Usuarios, Real Decreto Legislativo 1/2007 16 Noviembre.



**FONESTAR** is a member of ECOEMBALAJES ESPAÑA, S.A. "ECOEMBES", with number 03497 and all our products carry the symbol, backed by our membership and subscription to the above mentioned organization with the recycling and subsequent management of our packaging.

FONESTAR S.A. - NIF A28780443 - Apartado 191 - 39080 - Santander, Cantabria, (Spain)

[www.fonestar.com](http://www.fonestar.com)