



SAL-604N, SAL-604P

PAIR OF WALL MOUNTS FOR LOUDSPEAKERS

FONESTAR

DESCRIPTION

- Pair of adjustable wall mounts for loudspeakers.
- Tilt and turn arm.
- Maximum borne weight: 4 kg.
- Colour:
 - SAL-604N:** black.
 - SAL-604P:** silver.
- Dimensions:
 - total: 86 x 40 x 76 mm depth.
 - wall plate/mount for loudspeaker: 86 x 40 mm with holes for fixing the loudspeaker with screws.



ACCESSORIES INCLUDED

A	Fixing mount	4 u.
B	Joint	2 u.
C	Lag screw 5.5x42	4 u.
D	Lag screw 5x19	4 u.
E	Lag screw 4x18	2 u.
F	Wall plug	4 u.
G	Whitworth screw 1/4" x L 1/2"	4 u.
H	Whitworth screw 1/4" x L 7/8"	2 u.

I	Allen head bolt M6x19	2 u.
J	Bolt M5x19'5	2 u.
K	Bolt M5x16	2 u.
L	Bolt M4x16	2 u.
M	Copper nut	2 u.
N	M5 nut	2 u.
O	M3 Allen key	1 u.
P	M4 Allen key	1 u.

ASSEMBLY INSTRUCTIONS

- Make sure that the surface where you are going to install the mounts is resistant enough and completely flat. It is accompanied by 4 wall plugs and their corresponding lag screws for the installation of the mount as shown in the pictures.
- The mounts can be installed directly on the wall and to the loudspeaker or the intermediate joint can be used.
- Fix the mounts to the wall and tighten the screws. Then place the loudspeakers in the mounts and fix them with the appropriate bolts. Position the loudspeakers in accordance with your needs and tighten the bolts.



Assembly without joint

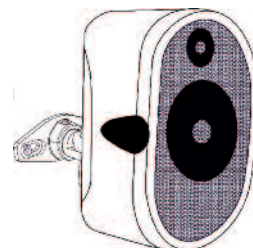
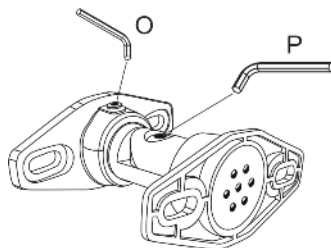

Assembly with joint

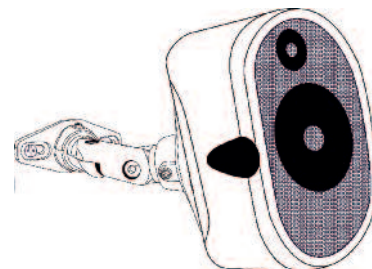
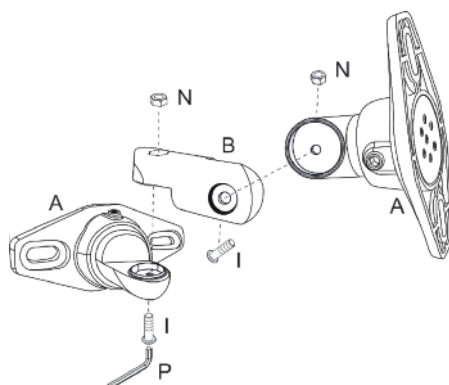

IMPORTANT

- The surface to be installed on must be resistant enough and completely flat. Correct installation on the wall, or surface, is necessary to ensure that the bracket supports the maximum weight. FONESTAR does not hold itself responsible, in any way, for damage or breakages that arise from the bracket coming away from the surface due to a faulty surface, incorrect installation or handling.

WARRANTY: 2 years against manufacturing defects, accompanied by proof of purchase. It does not cover breakages due to unsuitable use, the bracket falling away from the wall or installation surface, or postage. The warranty in no case covers damage suffered by equipment on the mount.



FONESTAR is a member of ECOEMBALAJES ESPAÑA, S.A. "ECOEMBES", with number 03497 and all our products carry the symbol, backed by our membership and subscription to the above mentioned organization with the recycling and subsequent management of our packaging.
 FONESTAR S.A. - NIF A28780443 - Polígono Trascueto - 39600 Revilla de Camargo, Cantabria, (Spain)
www.fonestar.com