



MWL 7,2-12 / MWL 7,2-12L

12V 7,2Ah

Compliance with standards

PN-EN 60896-21:2007
 PN-EN 60896-22:2007
 PN-EN 61056-1:2008
 PN-EN 61056-2:2003(U)

Batteries MW Power type MWL are designed for use mainly in emergency power systems e.g. UPS, emergency lighting, automation systems. The batteries can also be used in applications, where they operate cyclically. For discharges of 50% can reach 400 cycles.

Designed service life 10-12 years to range of 20-25 °C.



Specification

Nominal voltage	12V	
Nominal capacity	7,2Ah	
Dimensions	Lenght	151 mm
	Width	65 mm
	Height	94 mm
	Total height	100 mm
Weight	2,38 kg	

Dimensions

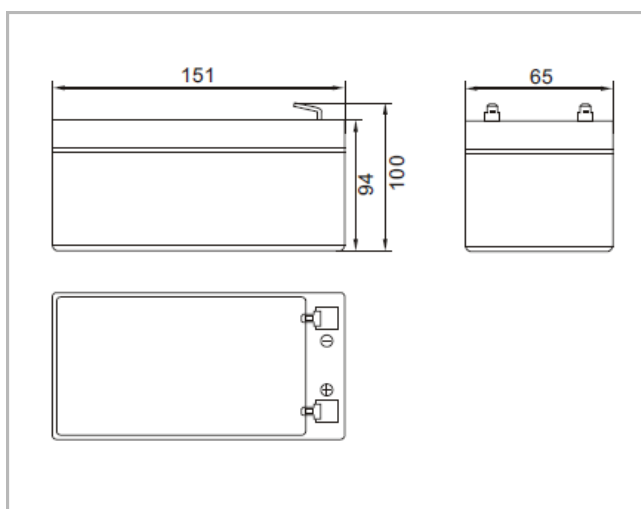

Characteristic

Capacity for 25 ° C and cut-off voltage 10.5 V	20h	7,2 Ah
	10h	6,6 Ah
	5h	6,1Ah
Internal resistance	charged battery	23 mΩ
Capacity	for 20°C	100%
	for 0°C	85%
	for -15°C	65%
Self-discharge	3 m-ths	91%
	6 m-ths	82%
	12 m-ths	64%
Terminal	Fast-on 187 (T1)/MWL 7,2-12	
	Fast-on 250 (T2)/MWL 7,2-12L	
Charging	Standby use	13,50-13,80V
	Cyclic use	14,40-15,00V
Max. charge current	2,4 A	
Max. discharge current	100 A (5 sec.)	
Temperatures of work:		
Discharging: -20°C ÷ 50°C		
Charging: -20°C ÷ 50°C		
Storage: -20°C ÷ 50°C		

Input-discharge at 25 ° C

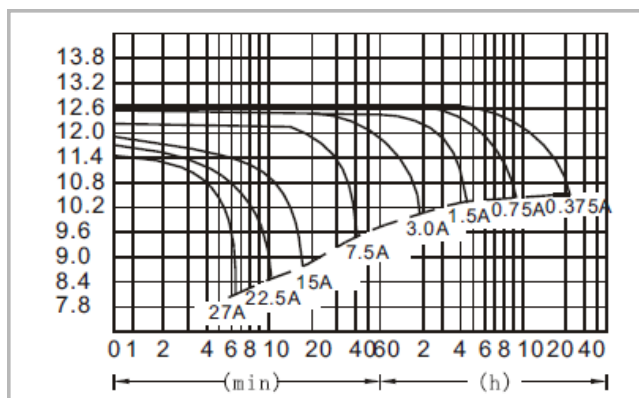

Terminal

