

DOT-60M, DOT-100M

LOW IMPEDANCE ATTENUATOR

ATENUADOR DE BAJA IMPEDANCIA
ATTÉNUATEUR DE BASSE IMPÉDANCE
ATENUADOR DE BAIXA IMPEDÂNCIA



QUICK START GUIDE/GUÍA RÁPIDA/
GUIDE DE DÉMARRAGE RAPIDE/GUIA RÁPIDO

FONESTAR

DESCRIPTION/DESCRIPCIÓN/DESCRIPTION/DESCRIÇÃO

EN

- Low impedance mono attenuator
- 6-position potentiometer with off switch
- **DOT-60M:** 60 W maximum
- **DOT-100M:** 100 W maximum

ES

- Atenuador de baja impedancia mono
- Potenciómetro de 6 posiciones con apagado
- **DOT-60M:** 60 W máximo
- **DOT-100M:** 100 W máximo

FR

- Atténuateur de basse impédance mono
- Potentiomètre de 6 positions avec arrêt
- **DOT-60M:** 60 W maximum
- **DOT-100M:** 100 W maximum

PT

- Atenuador de baixa impedância mono
- Potenciómetro de 6 posições com desativação
- **DOT-60M:** 60 W máximo
- **DOT-100M:** 100 W máximo

CONNECTION/CONEXIÓN/CONNEXION/LIGAÇÃO

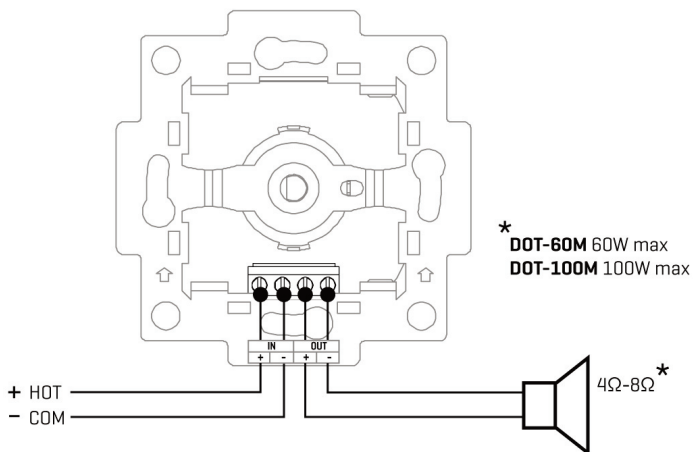

INSTALLATION/INSTALACIÓN/INSTALLATION/INSTALAÇÃO

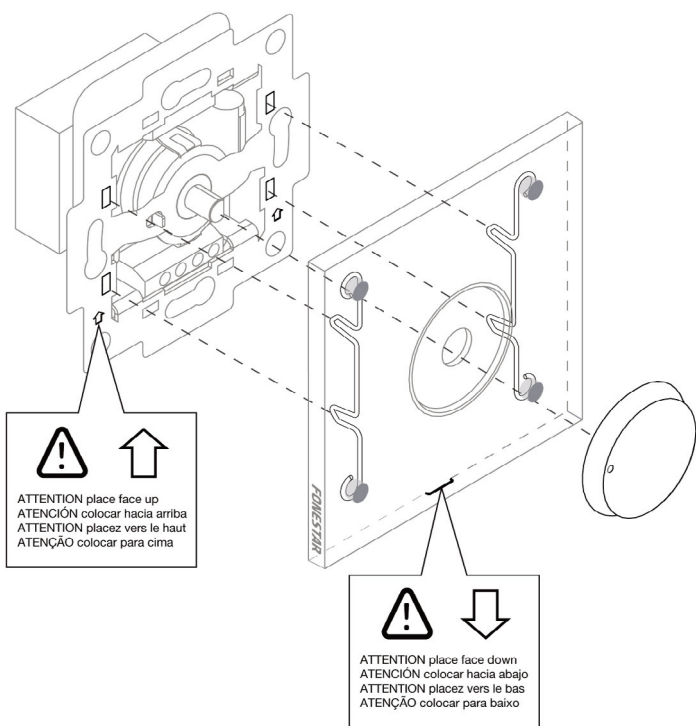

COMPATIBLE WITH (NOT INCLUDED)

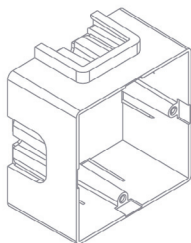

UNIVERSAL SQUARED
PLASTERBOARD INSTALLATION BOX

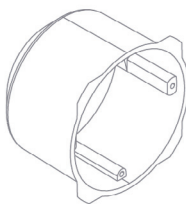

UNIVERSAL ROUNDED
PLASTERBOARD INSTALLATION BOX

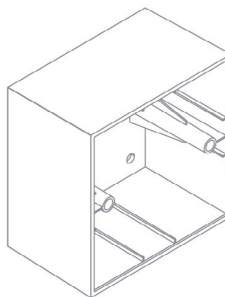

SURFACE BOX: DOT-BOX-B
DOT-BOX-N